

# I-SERIES

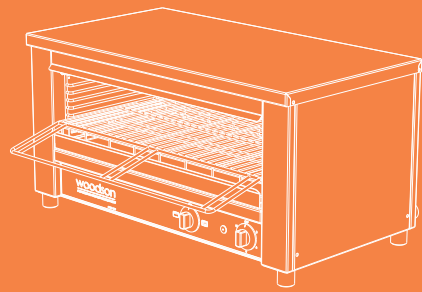

## W.GTQI.15 toaster/grillers

### APPLICATIONS

- Ideal for grilling or toasting foods in commercial cooking applications

### CAPACITY GUIDE

- 15 slices - 575mm x 345mm rack
- Large 105mm height opening

### FEATURES & BENEFITS

- Unique infrared glass elements with increased strength and durability providing long lasting reliability
- Incredibly even heat distribution for consistent cooking results
- Infrared elements provide immediate heat, with no need to leave the appliance running all day wasting energy
- Top and bottom elements with energy saving option of top element operation only
- New, multiple position slides and rack for easier and safer loading and unloading
- Extremely reliable - no troublesome fans or electronics
- Timer controlled operation only, guarantees power saving
- Stainless steel construction with new brushed finish
- Easily cleaned removable crumb tray



The instant heat of the infra-red elements



Now with more control of the cooking process

## W.GTQI.15

### W.GTQI.15 SPECIFICATIONS

Amps	15	3.5kW
W	725	D 420
		H 375

Dealer:

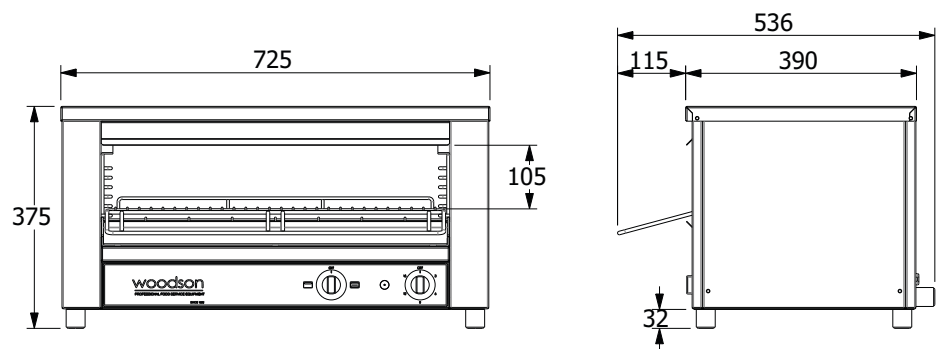

We reserve the right to alter specifications of products without notice

**For details of  
your local  
dealer, contact:**

**QLD**  
Tel: 07 3344 2444  
Fax: 07 3345 6403  
fse@stoddart.com.au

**NSW**  
Tel: 02 8832 4399  
Fax: 02 8832 4355  
sydney@stoddart.com.au

**VIC & TAS**  
Tel: 03 9565 4699  
Fax: 03 9565 4655  
melbourne@stoddart.com.au

**WA**  
Tel: 08 9414 1343  
Fax: 08 9414 1361  
perth@stoddart.com.au

**SA & NT**  
Tel: 1300 79 1954  
adelaide@stoddart.com.au