

SLIDING DOOR MERCHANDISER

≡ FEATURES & BENEFITS ≡

- **Energy conserving fan control**
Utilizing algorithmic air circulation for optimal temperature levels, our innovative fan control system conserves energy by at least 15% and increases compressor life by up to 30%.
- **LED advertising panel**
LED lighting offers 5 times longer lasting life than fluorescents and conserves energy as well.
- **LED lighting interior**
Brighter and longer lasting LED lights provide attractive, enhanced illumination compared to fluorescents. It saves energy by producing less heat, while maximizing the visibility in the display area.
- **Double pane glass doors with Low-E glass**
Energy saving double pane glass doors are equipped with Low-emissivity glass, which reduce outer heat gain and decrease energy consumption. It enhances energy efficiency and minimizes condensation. Lightweight door construction also reduce door maintenance and bushing wear, which in turn facilitates smoother door openings.
- **Efficient refrigeration system**
Turbo Air's glass door refrigerators are designed with oversized and balanced (CFC Free R-134A) refrigeration systems. These include efficient evaporators and condensers for faster cooling and greater efficiency.
- **Adjustable, heavy duty, PE (polyethylene) coated wire shelves**
- **Bottom mount compressor unit**
- **Ergonomically designed doors with easy grip handles**
- **Magnetic door gasket**
- **High-density polyurethane insulation**
The entire cabinet structure is foamed-in-place using high density, CFC free polyurethane insulation.



Refrigerator holds 33°F ~ 38°F for the best in beverage preservation



Model	Sliding Door	CU./FT.	#of Shelves	HP	AMPS	Crated Weight (lbs.)	L x D* x H (inches)
FRS-1000R	2	35	8	1/2	10.9	419	413/8 x 30 x 79 1/8

SLIDING DOOR MERCHANDISER

GLASS DOOR MERCHANDISERS
REFRIGERATORS
MODEL : FRS-1000R

Model : FRS-1000R

ELECTRICAL DATA	
Voltage	240/50/1
Full Load Amperes	10.9
Compressor HP	1/2
Cord Length (ft.)	6
Refrigerant	R-134A
DIMENSIONAL DATA	
# of Doors	2
Net Capacity (cu. ft.)	35
Ext. Length Overall (in.)	41 ³ / ₈ (1052mm)
Ext. Depth Overall (in.) *	30 (762mm)
Ext. Height Overall (in.)	79 ¹ / ₈ (2010mm)
Int. Length Overall (in.)	37 ⁷ / ₈ (960mm)
Int. Depth Overall (in.)	24 ¹ / ₂ (622mm)
Int. Height Overall (in.)	61 ¹ / ₄ (1556mm)
Net Weight (lbs.)	410
Gross Weight (lbs.)	419
# of Shelves	8
Shelf Size (L x D) (in.)	18 x 23 ³ / ₈
Bottle Capacity (Full/Load line)	420 / 336

Design and specifications subject to change without notice.
Actual shipping weight may differ due to extra packing materials for product protection.
* Depth does not include 3/4" for door handle.

- **White color cabinet & black color frame on door**
- **4" dia. casters are available (optional)**
- **OPTIONAL ACCESSORIES :**
 - 4" caster, 1/2" diameter & 13 TPI: G8F6500101 (non-brake), G8F6500201 (w/ brake)
 - Additional PE coated wire shelf: 30278A0207 (LED unit)

PLAN VIEW

(unit : inch)

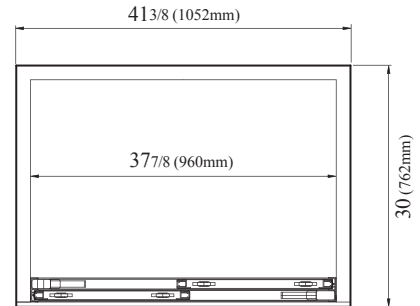

PLAN VIEW

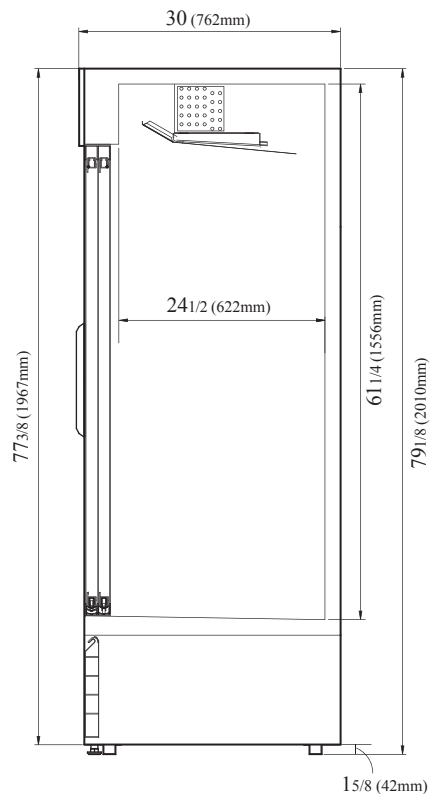

SIDE VIEW

AUSTRALIA BRANCH

Turbo air

TURBO AIR PTY LTD
www.turboairinc.com.au
1st Floor, Building E
10 Highgate St, Auburn
NSW 2144 Australia
T. 02 9737 9881