

specifications

RF8.PPZ.4.SD

ReFlex Series, 4 Solid Door Large
Pizza Preparation Fridge

Project: _____

Item No: _____

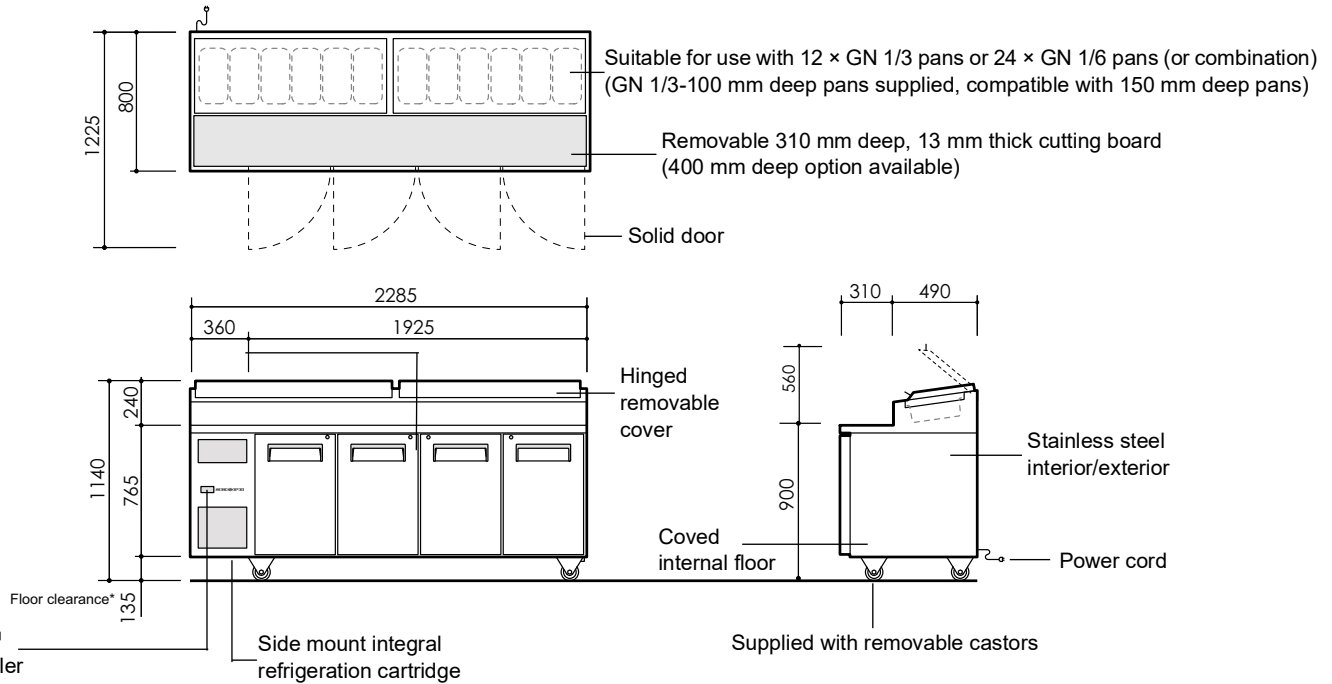

SKOPE-connect™
compatible controller

Side mount integral
refrigeration cartridge

Supplied with removable castors

CABINET

Doors	4 × self-closing, lockable, solid swing doors with stay-open position at over 90°, hinged LH, LH, RH, RH
Internal door opening	4 × door openings: 590 mm high × 370 mm wide
Shelves	8 × adjustable height shelves. Middle shelves: 475 mm wide × 610 mm deep. Outer shelves: 415 mm wide × 610 mm deep. Each shelf is held in place with 4 × shelf clips. Additional shelf clips are available on request.
Worktop	Removable, food grade, 13 mm plastic cutting board
Material	304 AISI stainless steel interior and exterior

PERFORMANCE

Max. ambient temperature	40°C (lid(s) closed), or 30°C (lid(s) open)
Temperature range	1°C to 5°C (adjustable with SKOPE-connect™ -2°C to 15°C)
Total energy consumption	5.83 kWh/24 h (@ 30°C/55% relative humidity)
Annual running cost	\$639 p.a. (@ \$0.30/kWh)

ELECTRICAL

Electrical safety climate class	5 (40°C/40% relative humidity)
Interior lighting	3 × 400 mm, 4W LED lights (door activated)
Power cord	Supplied with a 10 amp plug and 2 m lead
Power supply	220-240 volts a.c. 50 Hz, single phase supply
Current draw	3.5 amps (includes unit 2.2 amps)

REFRIGERATION

Controller	SCS Connect (SKOPE-connect™ compatible)
Connectivity interface	Bluetooth® wireless technology
Refrigeration system	Side-mounted, integral, removable refrigeration cartridge (part number ULQCN1-0030)
Refrigerant	R290/90 g (natural refrigerant)
Nominal capacity	900 watts
Heat rejection (Avg./peak)	250 watts/300 watts
Drainage	No plumbing required in standard applications. If lids are left open for more than 4 hours per day, or venues have high or fluctuating ambient temperatures and humidity, SKOPE recommends connecting condensate to an in-floor drain.

DIMENSIONS

	External	Internal
Height	1140 mm	605 mm
Width	2285 mm	1835 mm
Depth	800 mm	640 mm
Floor area	1.83 m ²	
Weight	233 kg	
Gross volume	710 L	

Height variation

Supplied castors	1140 mm
Height adjustable legs	1150 to 1200 mm
No castors	1005 mm

Dimensional tolerances

Before installing this cabinet allow the following dimensional tolerances:

Linear dimensions	Overall cabinet dimensions	
Less than 1 metre	±5 mm	
More than 1 metre	-5 mm to +10 mm	
	Length of multiple cabinets	
	At each joint	At each end wall
Less than 1 metre	±5 mm	+15 mm
More than 1 metre	-5 mm to +10 mm	+15 mm

Ventilation requirements

Top	Not required
Sides	Not required
Back	Not required
Bottom	Not required