



# 800 SERIES FRYER

## 3 baskets

## TGF24ML - Gas

- Turbo gas tube type fryer provides a quick recovery along with the benefit of energy efficiency
- Large cool zone for long oil life
- Stainless Steel pan for easy cleaning
- Stainless Steel baskets
- Cover/joiner strips available for multiple unit installations
- Line-up nosing

### Other options

Night lid

Cover/joiner strips

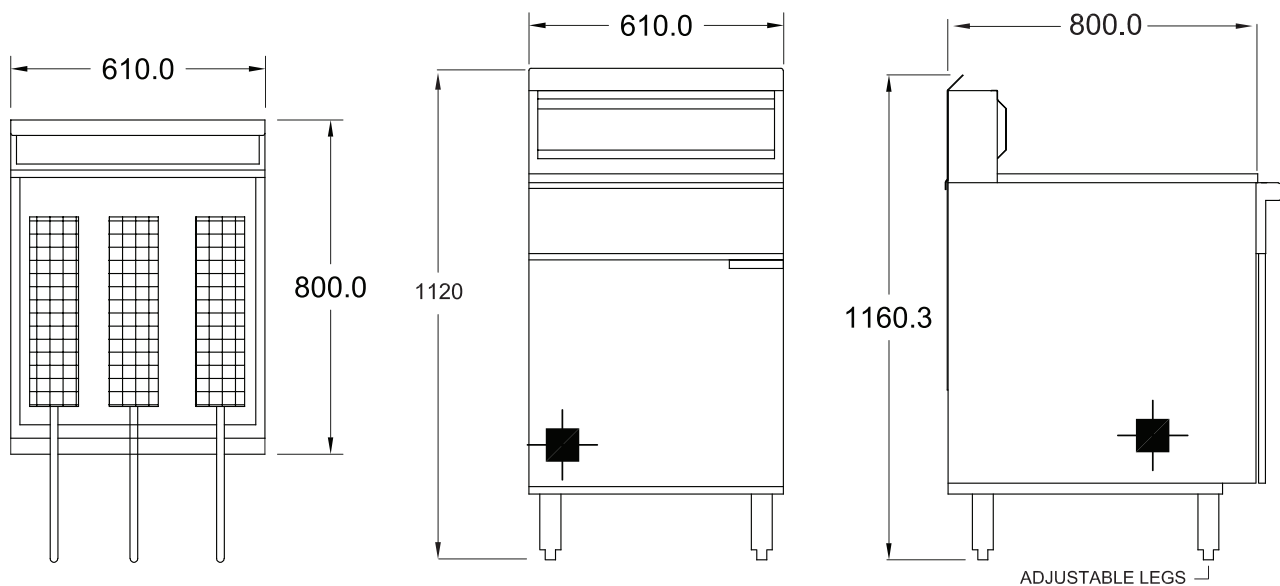

## TGF24L 3 baskets

### SPECIFICATIONS

<b>Dimensions (WxDxH)</b>	610 x 800 x 1120 mm
<b>Working height</b>	900 mm (±20 mm)
<b>Pan Size (WxDxH)</b>	565 x 355 x 203 mm
<b>Capacity</b>	48 L

3/4" BSP Gas Connection

<b>Gas Connection</b>	3/4" BSP
<b>Rating</b>	147 Mj (NG) / 116 Mj (LP)
<b>Weight</b>	90 kg
<b>Packed</b>	0.6 m <sup>3</sup>

Australia's premier food service  
equipment manufacturer

[goldstein.com.au](http://goldstein.com.au)

211-217 Woodpark Road, Smithfield NSW 2164  
1800 013 123 | +61 2 9604 7333

 **MIDDLEBY AUSTRALIA**

