



800 SERIES FRYER

2 baskets

FRGIL - Gas

- Flat bottom fryer for maximum food type flexibility
- Unique pan design maximises heat transfer to minimise energy use
- Stainless Steel baskets
- Stainless Steel pan for easy cleaning
- Front cool zone with crumb arrester for longer oil life
- Cover/joiner strips available for multi-unit installations
- Line-up nosing

Other options

Night lid

Cover/joiner strips

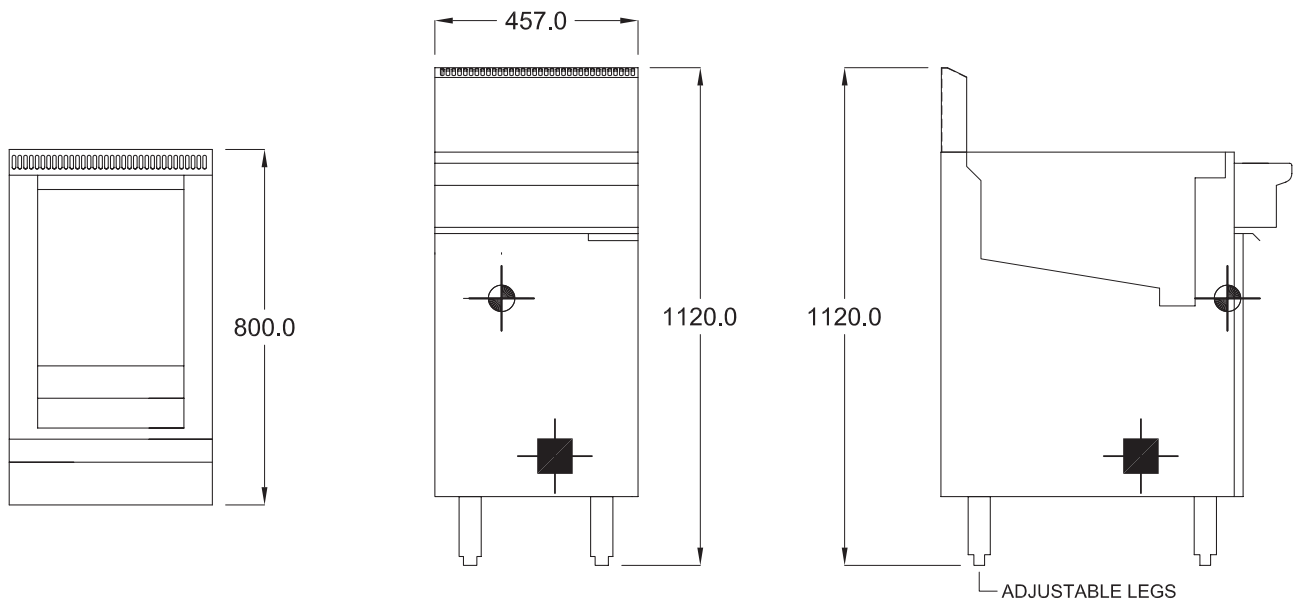

FRGIL 2 baskets

SPECIFICATIONS

Dimensions (WxDxH)	457 x 800 x 1120 mm
Working height	900 mm (±20 mm)
Pan Size (WxDxH)	330 x 475 x 203 mm
Capacity	32 L

■ 3/4" BSP Gas Connection

⊕ Drain

Gas Connection	3/4" BSP
Rating	80 MJ
Weight	70 kg
Packed	0.5 m ³

Australia's premier food service equipment manufacturer

goldstein.com.au

211-217 Woodpark Road, Smithfield NSW 2164
1800 013 123 | +61 2 9604 7333

 **MIDDLEBY AUSTRALIA**

