

GLASS DOOR MERCHANDAISER

FREEZER
MODEL : TGF-35SD

FEATURES / BENEFITS

- DIGITAL TEMPERATURE CONTROL SYSTEM**
Provides precise and constant temperature. This level of precision allows food products to remain fresh over an extended period of time.
- HIGH-TECH MONITOR**
The unit will beep if the door has been opened for more than 30 seconds. The monitor digitally displays the present temperature and current status of the freezer. You can easily change the temperature by adjusting the thermostat.
- SMART DEFROST SYSTEM**
Generally, a refrigerator's defrost timer defrosts automatically for a fixed length of time regardless of the existing conditions of the refrigerator. This makes it difficult to maintain a constant temperature and also consumes unnecessary energy. Turbo Air's "Smart Defrost System" analyzes its surrounding environments and defrosts only when it is needed for the required time. This not only saves energy but also keeps the contents of the refrigerator safe.
- NO ELECTRICAL FRAME HEATER IS NEEDED**
Turbo Air is the first in the industry to replace a frame heater with a method of using compressor-produced heat. This eliminates any unnecessary energy consumption while providing efficient freezing performance.
- ENERGY CONSERVING FAN CONTROL**
Utilizing algorithmic air circulation for optimal temperature levels, our innovative fan control system conserves energy by at least 15% and increases compressor life by up to 30%.
- SHADOW FREE ADVERTISING PANEL**
Turbo Air is the pioneer in the refrigerator industry on applying special LED Light Guided Panels (LGP). LGP increases panel visibility and eliminates shadows, thus enhances any store atmosphere with eye-catching effects. LED lighting offers 10 times longer lasting life than fluorescents and conserves energy as well.
- LED LIGHTING INTERIOR DISPLAY SYSTEM**
Brighter and longer lasting LED lights provide attractive, enhanced illumination compared to fluorescents. It saves energy by producing less heat, while maximizing the visibility in the display area.
- DOOR OPENING ALARM**
If the doors are not tightly closed, the refrigerator will not run. This would cause the cold air to escape through the opening, making food products spoil inside the cabinet. To prevent this problem, our refrigerators are equipped with the Door Alarm System that will sound if the doors are left open for more than 30 seconds.
- EARLY WARNING SYSTEM**
Malfunctions are generally recognized when an increase in temperature is detected, 2 to 3 hours after the refrigerator had stopped running. This causes the user to become aware of malfunction issues the next morning in which the contents may have already spoiled. To eliminate this, Turbo Air units have a warning system in place that diagnoses and monitors itself for risk factors, which gives an early warning signal in the form of an audible alarm to eliminate product loss and future service issues.
- TRIPLE PANE AIR INSULATED LAYER GLASS DOORS & INSULATED CABINET CONSTRUCTURE**
Equipped with unique triple pane glass doors with a layer of patented, transparent thermal insulating film applied between the glass layers. Lightweight door construction reduces door maintenance and roller/bushing wear, and facilitates smooth door opening. The cabinet structure is foamed-in-place, high density polyurethane insulation.



TGF-35SDB

TGF-35SDW

Model	Swing Door	Capacity (litres)	#of Shelves	HP	AMPS	Crated Weight (kg)	W x D x H (mm)
TGF-35SD	2	1048	8	1+1/4	7.5	206	1004 x 809 x 2136

GLASS DOOR MERCHANDAISER

FREEZER

MODEL : TGF-35SD

Model :TGF-35SD

PLAN VIEW

(unit : mm)

SPEC SHEET	TGF-35SD
Classification	Freezer
Cabinet dimension (WxDxH mm)	1004x809x2136
Capacity (Liters)	1048
Inner Temperature	-24°C ~ -16°C
Ambient Temperature	38°C
Doors	2
# of shelves	8
Refrigerant	R-404a
Compressor (HP)	1+1/4
Cooling Type	Fan cooling type
Insulation Type	Polyurethane/ Cyclopentane+CFC Free
Temperature Control Type	Digital
Amps (A)	7.5
Voltage (V/Hz/Ph)	240V 50Hz 1Ph
Power (W)	1575
Weight (Kg)	206

Design and specifications subject to change without notice.
Actual shipping weight may differ due to extra packing materials for product protection.

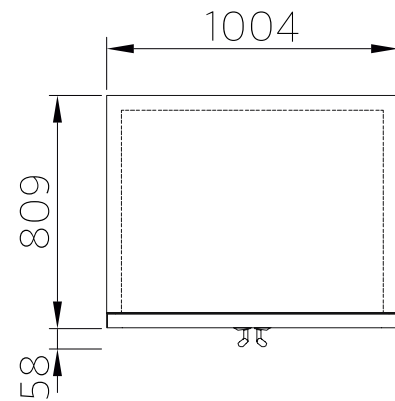

TOP VIEW

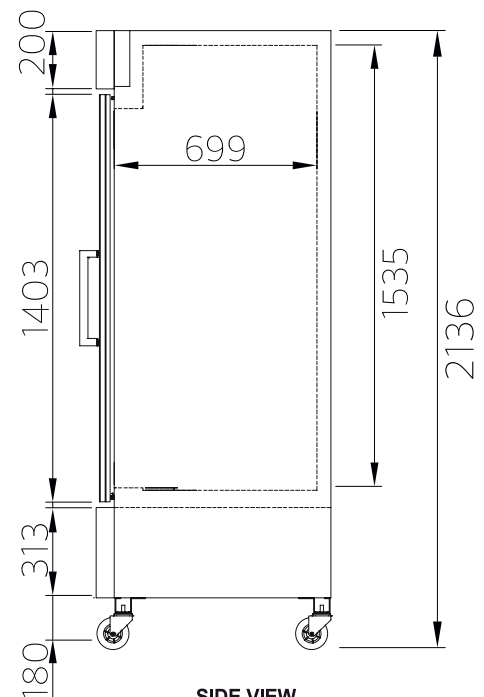

SIDE VIEW

- **TWO COLOR OPTIONS AVAILABLE (STANDARD)**
Super Deluxe series comes in white cabinet (W) or black cabinet with black color trim (B).
- **DOOR LOCKING SYSTEM STANDARD**
- **LOW-E + TRIPLE HEATED GLASS STANDARD**
- **4" SWIVEL CASTERS STANDARD**

WARRANTY **2 YEARS**
PARTS & LABOUR



AUSTRALIA BRANCH

Turbo air

TURBO AIR PTY LTD
www.turboairinc.com.au
 Ground floor, Building E
 10 Highgate St, Auburn
 NSW 2144 Australia
 T. 02 9737 9881