



manufactured fun

PARAGON

OWNER'S MANUAL

FOR PROFESSIONAL SNO CONE MACHINES



Model Numbers

1911 SNO-STORM
6133110 (120V)
6233110 (230V)

THE BLIZZARD
6133210 (120V)
6233210 (230V)

THE BLAST
6133310 (120V)
6233310 (230V)

THE COOLER
6133410 (120v)

Sno-Cone Machines

www.ManufacturedFun.com

Paragon International, Inc • 731 W. 18th Street • P.O. Box 560 • Nevada, IA 50201 USA
Phone (515) 382-8000 • Toll-free (800) 433-0333 • Fax (515) 382-8001 • Email: info@manufacturedfun.com

SAFETY PRECAUTIONS

Paragon values your continued safety above all else. Please follow these guidelines when using your equipment to prevent injury and maximize product performance:



No direct contact to equipment by the general public should be allowed when used in food service locations. Only trained personnel should operate this equipment. Carefully read any and all instructions before beginning operation of the equipment.



Always wear safety glasses when servicing equipment.



Shaver reaches high speeds during operation. To avoid injury, NEVER place body parts or objects such as ice picks into or near the shaver head assembly while motor is running. *Paragon is not responsible for any injuries that may occur due to failure to follow safety precautions.*



Any alterations made to equipment by anyone other than certified Paragon personnel will void warranty and may also create unsafe working conditions. NEVER make alterations to the equipment.

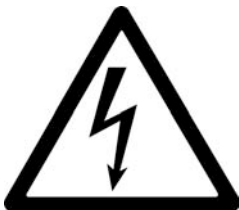

Machine must be properly grounded to prevent electrical shock. Do NOT immerse any other part of this equipment in water. Doing so may damage equipment and prevent it from working properly. Always unplug equipment before cleaning or servicing to prevent electric shock.

INTRODUCTION

PARAGON IS PROUD TO BE YOUR PARTNER FOR MANUFACTUREDFUN.

Our goal is to provide you with the best solutions to attract customers, expand your business, and improve your profits. That's why this product has been specially-crafted to meet precise specifications for performance, efficiency, and output.

Your Paragon Sno-Cone Machine features:

- Sturdy, cast-aluminum components and stainless steel blades that are adjustable and easy to replace.
- A colorful back-lit sign to attract customers. (Included on 1911 Sno-Storm and Blizzard machines only.)
- Heavy-duty, 1/3 hp motor with 1725 rpm, featuring a convenient manual safety reset to prevent accidental start-up in the case of a jam.
- Slanted drain deck is removable. Made of food grade plastic, engineered to drain moisture away from the ice and extend shelf life. (Slanted drain deck is incorporated into the design of The Cooler)
- Stainless steel and aluminum construction that withstands heavy commercial use and maintains attractive appearance.
- Tinted high-impact polycarbonate to enhance the view of the product – plus, they're easy to clean and completely shatterproof.
- Lighted serving compartment to provide an attractive display setting for increased impulse buying and operator ease. (Included on 1911 Sno-Storm and Blizzard machines only.)

Should you have any questions about your equipment, or would like to know more about our other innovative concession equipment and supplies, please contact us at 1-800-433-0333 or visit us on the web at: **Manufacturedfun.com**

Thank you for your purchase and enjoy!

ELECTRICAL REQUIREMENTS

This product requires a properly-grounded 120 volt supply with a 15 amp circuit. The Sno-Storm and The Blizzard have a current draw of 5.7 amps; The Blast and The Cooler have a current draw of 5.3 amps. (Export voltage is 230VAC.)

We recommend your Paragon Sno-Cone Machine be plugged directly into a dedicated outlet. Extension cords may create a safety hazard and reduce its performance.

Be sure outlet accepts three (3) prong grounded plug. DO NOT use a three (3) prong to two (2) prong adapter.

UNPACKING

Paragon carefully inspects each product during assembly and after completion to adhere to strict quality guidelines, and packs it securely to ensure safe delivery to each of our customers. Be sure to carefully remove all packing material and adhesive before any operation. Please examine your product to guarantee all equipment has arrived, complete and in good condition.

If you believe that any damage may have occurred during shipment or parts may be missing, please contact Paragon immediately for replacement.

FREQUENTLY ASKED QUESTIONS

How much will my sno-cone machine produce?

Your sno-cone machine was engineered to shave 500 lbs. of cube or chunk ice per hour. Based on the ratio that a 1/2 lb. of ice will make a 6 oz. sno-cone, the Paragon Sno-Cone Machine will yield 1000 sno-cones per hour.

How much syrup should I use to flavor my sno-cones?

One 6 oz sno-cone will take 2 ounces of syrup – cones will not hold more than that.

Can I use block ice to make sno-cones?

You can use block ice to produce sno-cones if you first break it down into pieces 3-4 inches in size. Ice will not fit the horn if the pieces are too large.

OPERATING INSTRUCTIONS

Be sure equipment is connected to properly grounded 120 volt power supply with 15 amp circuit. (230 volts for export models)

Shaving Ice

1. Turn POWER switch ON (Not used on The Cooler and The Blast).
2. Fill the ice horn with ice.
3. Press and hold the MOTOR switch to activate blades and begin shaving ice.
4. While holding MOTOR switch down, apply steady downward pressure to the ice pusher
5. Release the MOTOR switch when finished.
6. Repeat steps 2-5 for additional batches.

Cleaning Procedures

1. Remove all ice from the ice horn and storage compartment.
2. Operate the motor for several minutes to remove any water collection on the cutter head.
3. Turn off the POWER switch. (Not used on all models.)
4. Unplug the power cord from the electrical outlet.
5. Using a clean cloth, wipe down the following items.
 - The inner surface of the ice horn (Caution: Sharp Blades)
 - The outside surface of the ice horn casting.
 - The ice pusher.
 - All interior and exterior surfaces.
6. To clean the water collection tray.
 - Tilt tray to drain the water trapped in the drain cavity.
 - Slip the drain hose off the nipple fitting.
 - Lift the tray out of the cabinet
 - Clean tray and area below tray with clean cloth.

Note: FDA approved cleaners may be used when required for sanitation. Do not use ammonia based cleaners on polycarbonate door and/or side panels.

BLADES ARE SHARP AND OPERATE AT HIGH SPEEDS! Please be sure to keep all body parts and any objects such as picks or scoops away from the ice horn while POWER is on!

MAINTENANCE OF CUTTING HEAD

Remove the Cutting Head (*Caution: Sharp Blades*)

1. Turn off the POWER switch. (Not used on all models.)
2. Unplug the power cord from the electrical outlet.
3. Rotate the cutting head until the set-screws are accessible through the discharge opening located inside the top panel of the storage cabinet.
4. Use a 1/8" hex wrench to loosen the set-screws.
5. Slide the cutting head off the motor shaft and remove the cutting head out of the top side, inlet, of the ice horn.

Cutting head blade replacement

1. Remove the two screws per blade.
2. Lift the old blades out.
3. Position the new blades on the head with the cutting edge extending between 1/32" to 1/16" out from the cutting head surface. This setting will control the granular size of the ice.
4. Use the blade screws to secure the blades to the head.

Installing the Cutting Head

1. Slide the cutting head down into the ice horn with the coupler end first.
2. As the cutting head is slipped onto the motor shaft, align the set screws to the flat location of the motor shaft.
3. Tighten the setscrews with a 1/8" hex wrench.
4. Spin cutting head by hand to insure clearance with horn.
5. Machine is now ready for use.

1911 SNO-STORM/BLIZZARD CABINET ASSEMBLY

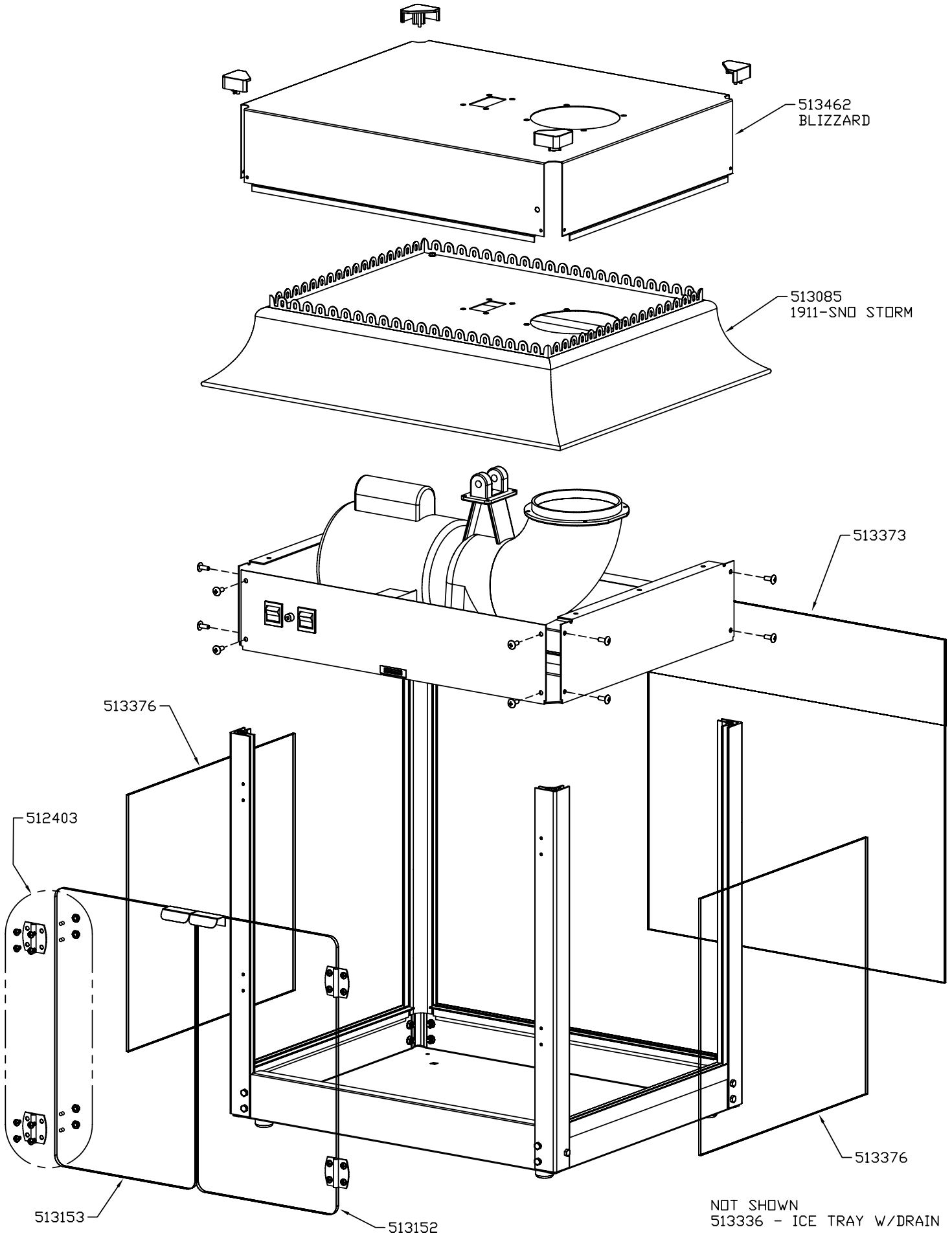

1911 SNO-STORM/BLIZZARD CHASSIS ASSEMBLY

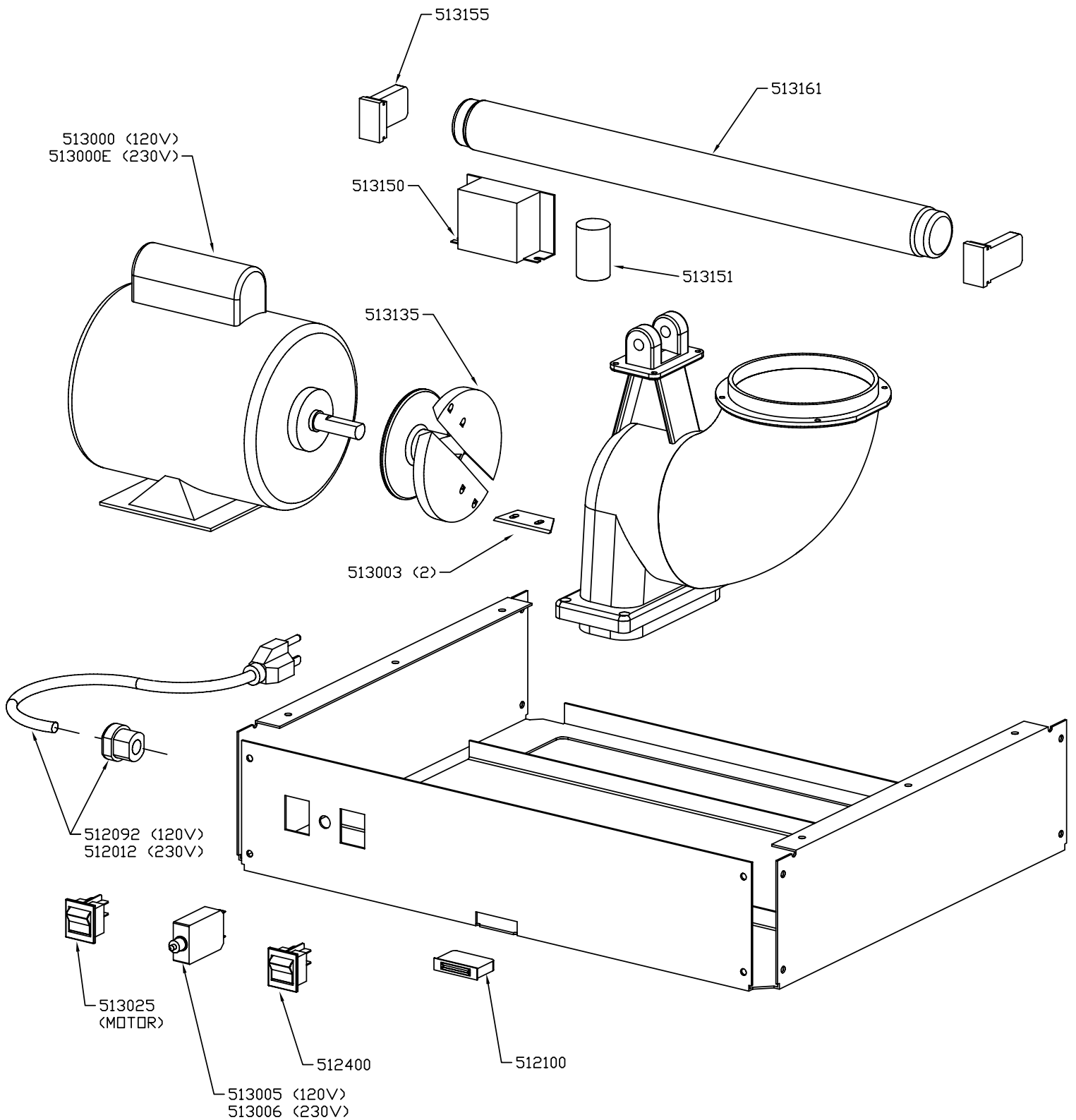

THE BLAST ASSEMBLY

NOT SHOWN
512100 - DOOR MAGNET

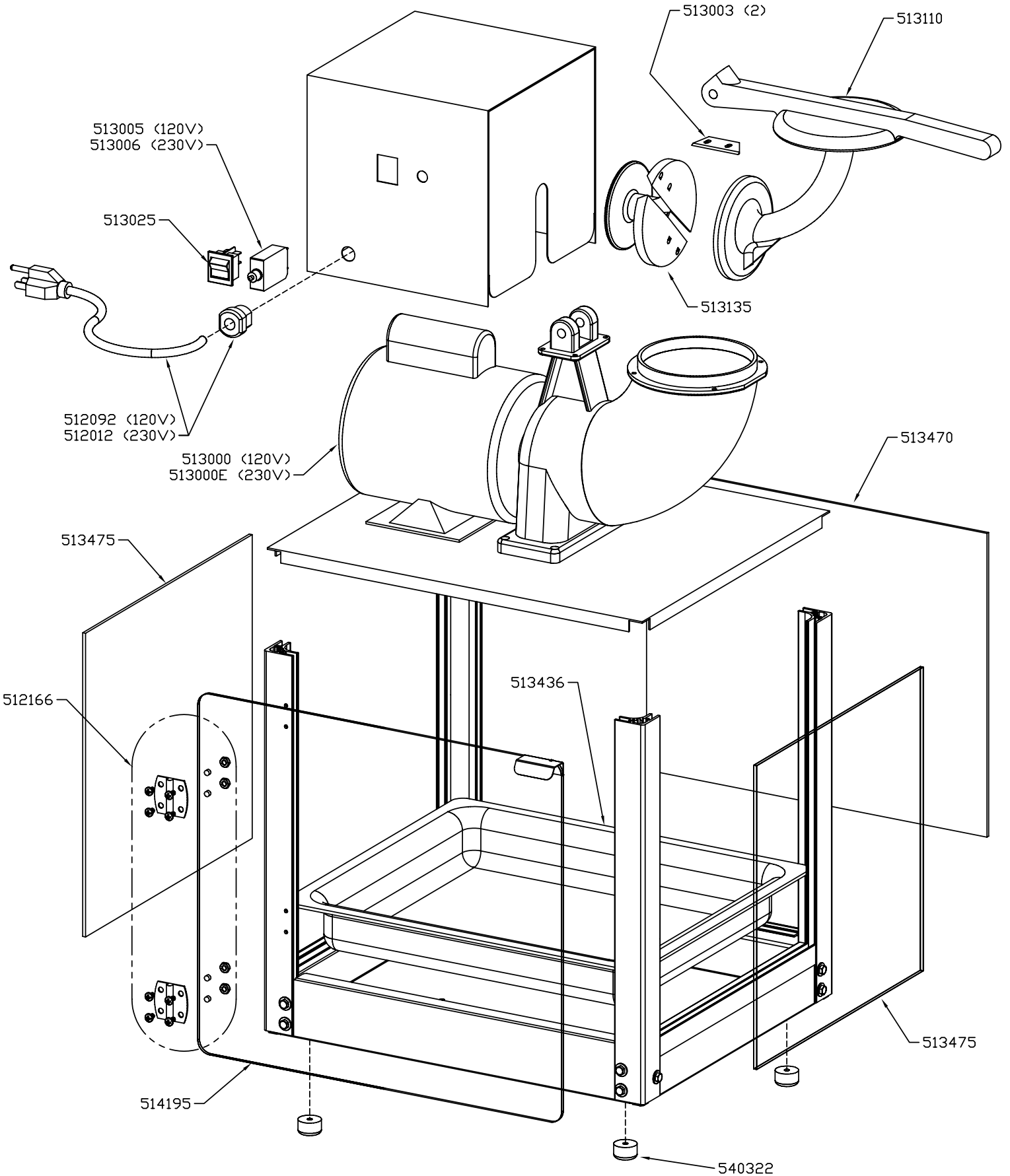

COOLER ASSEMBLY

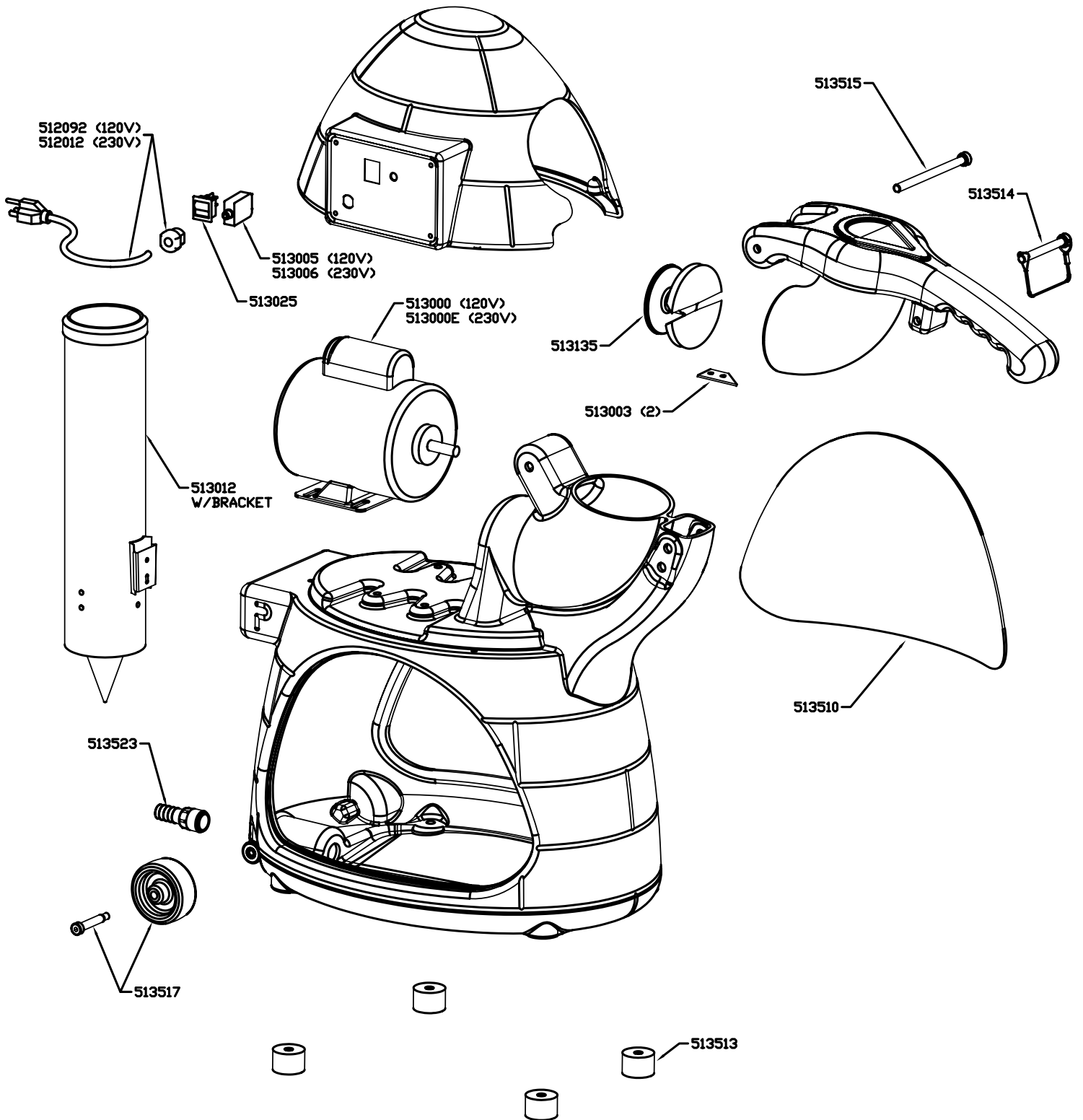

1911 SNO-STORM/BLIZZARD WIRING DIAGRAM

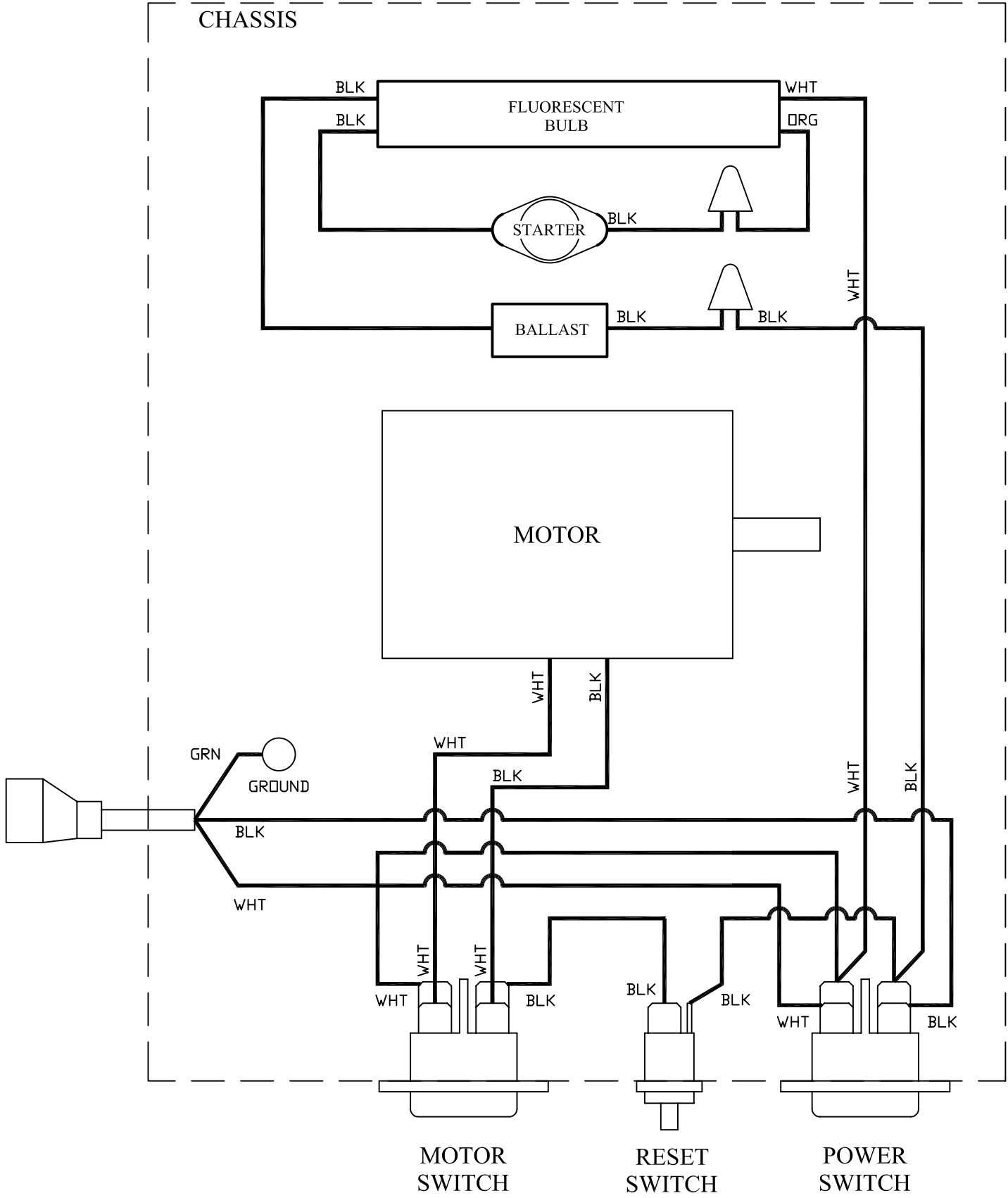

1911 SNO-STORM/BLIZZARD WIRING DIAGRAM (EXPORT ONLY)

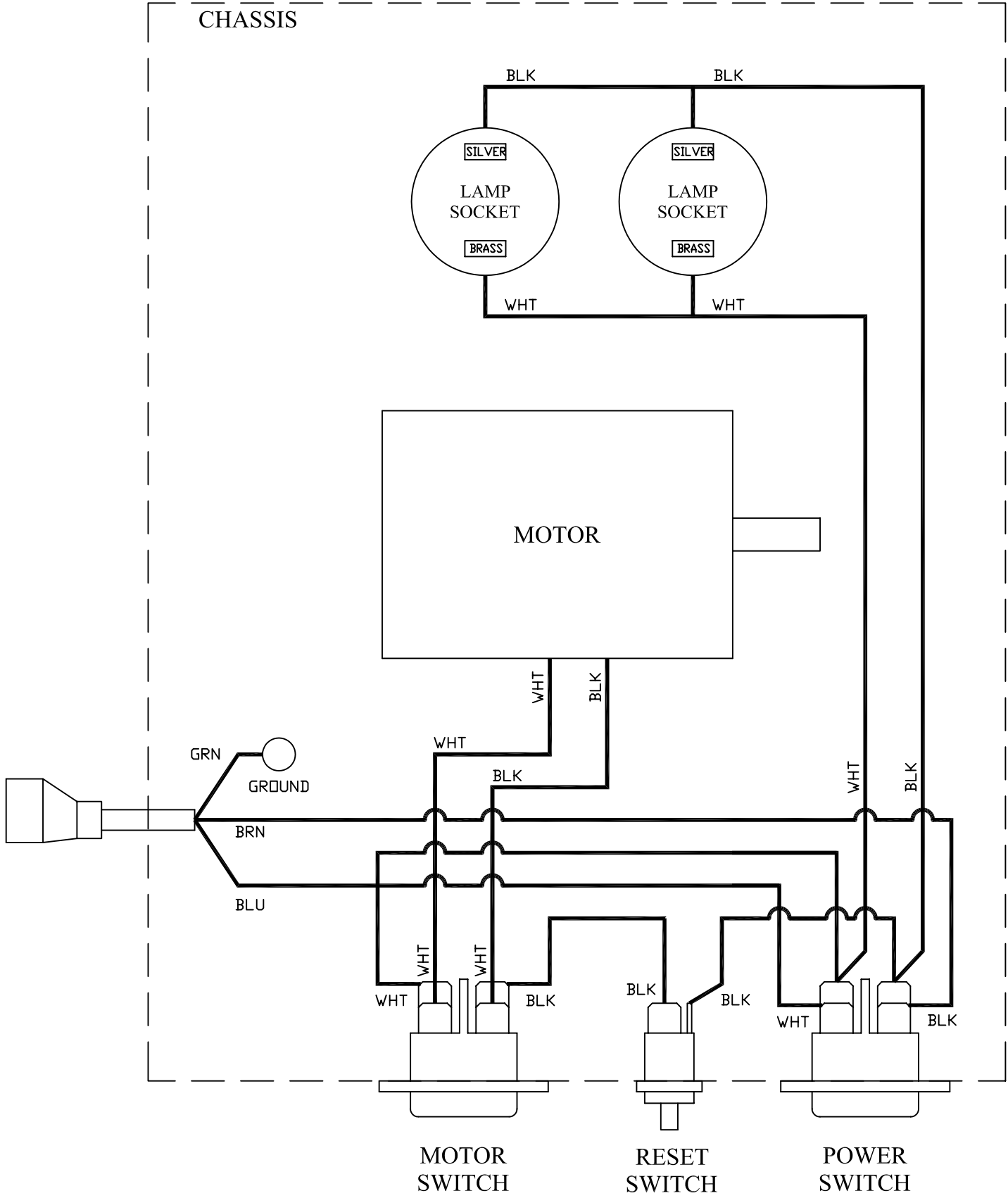

ARCTIC BLAST/COOLER WIRING DIAGRAM

