

DETAILS



1. Opening door alarm/Hi temperatura alarm
2. External cylindric handle in stainless steel (Steel color for X Version)
3. Inner assistance fan
4. Blue backlit main switch
5. Shelf with small distance between the line and bottom shelf fittes as standard

GENERAL FEATURES

200 Lt. Refrigerated upright (CLASS A++)	•
S/S external cabinet, thermoformed internally	•
Roll-bond evaporator system with fan assisted cooling	•
Automatic compressor cycle defrost	•
Foaming Agent Cyclopentane (50mm per side)	•
Digital Thermostat	•
Opening door alarm/Hi temperatura alarm	•
Removable Gasket	•
Reversible door with stainless steel external handle	•
Lock and main switch fitted as standard	•
Adjustable shelves: 2 Pcs + 1 Pcs Bottom	•
N.2 Adjustable feet + N.2 Rollers at the back	•
Energy efficiency class: A++	•

SIZES

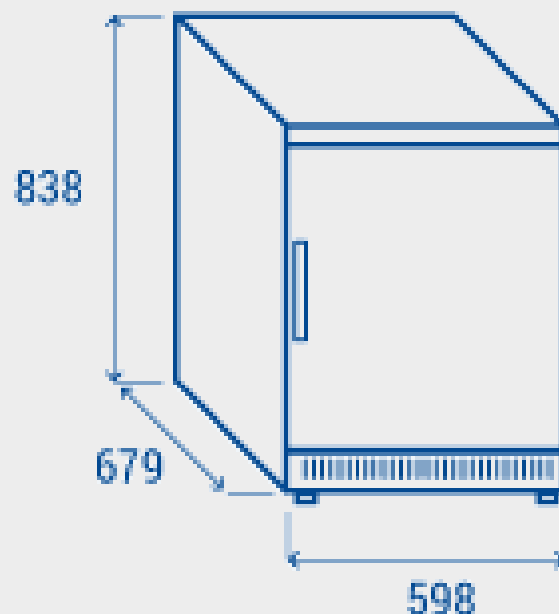

TECHNICAL SPECIFICATION

INNER DEPTH	443 mm
INNER HEIGHT	652 mm
INNER WIDTH	477 mm
DEPTH	679 mm
HEIGHT	838 mm
WIDTH	598 mm
KW/24H	0.37 Kw
CAPACITY	200 L
NOISE LEVEL	40 dB(A)
CONSUMPTION	56 W
NET WEIGHT	43 Kg
TEMPERATURE RANGE	+0°C ~ +8°C

CERTIFICATIONS

